



**Electricity &  
Solar Energy  
Investigations  
Teaching Guide**

## **Welcome to the BrightSparks 4kids-**

## **Electricity & Solar Energy Teaching Guide**

### **Introduction:**

This kit and range of modules are specifically designed to take away the 'fiddle factor' when teaching and learning about electricity and Solar energy.

The aim of this guide is to provide teachers with sufficient basic circuit knowledge to effectively teach Electricity and Solar energy using a real 'hands on approach' in collaboration with the range of **BrightSparks 4kids** products.

Children and students will be able to learn and enjoy building simple circuits in a safe and stimulating way. This will encourage them to use their knowledge and understanding to design circuits which can later lead to group discussions and further their understanding of electronics.

All components have been specifically designed with the teacher and user in mind, being durable and extremely hard wearing for today's classroom environment.

The colourful modules clearly display each component name and electrical symbol. Components are securely mounted and all connections between the modules are made by colour coded 4mm 'plug and socket' type stackable leads. The red terminal indicates positive (+) polarity and the black terminal indicates (-) negative polarity. Where yellow terminals are present this indicates no polarity. Therefore, leads can be connected either way.

The layout of each module has been designed so that the user can easily associate the linearity of a circuit and its need to be a complete loop. All component symbols are situated between the connecting sockets allowing a complete circuit path to easily be recognised.

Note: Some examples in this guide require additional modules and equipment such as voltmeters and current meters. These products are available separately from our website for more details please go to [www.brightsparks4kids.com](http://www.brightsparks4kids.com)

## Range of modules



A single battery is called a cell. Each battery safely supplies electrical energy to the circuit. The type of battery used in this kit is a 'C' type of 1.5Volts. If you look closely at the battery you will find it indicates this on its casing. Batteries have two polarities, one at either end. The positive polarity has a 'pip' and is indicated by a plus (+) and the negative polarity has a flatter side which is the minus (-). It is important when using batteries that you insert them correctly into each Battery holder module. The spring side located on the left is the negative and the flat side is the positive end on the right.

Connections are made from colour coded terminals, red being the (+) positive contact and black being the (-) negative contact. For safety each Battery module is short circuit protected.



***CAUTION*** must always be observed when using batteries. Do NOT allow 'short circuiting' of the +/- terminals. This is done by the + and - leads touching together and can result in excessive heat generation which may result in damage to the battery.

## Combining Cells

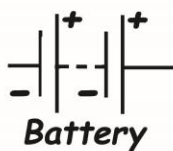

A single cell linked together is called a battery and they are often linked in series to combine output voltages.

Output ranges used in this kit are 1.5Volts (1 battery) 3.0Volts (2 batteries) 4.5Volts (3 batteries) and 6Volts (4 batteries).

## Examples of Cell Voltages connected in series:

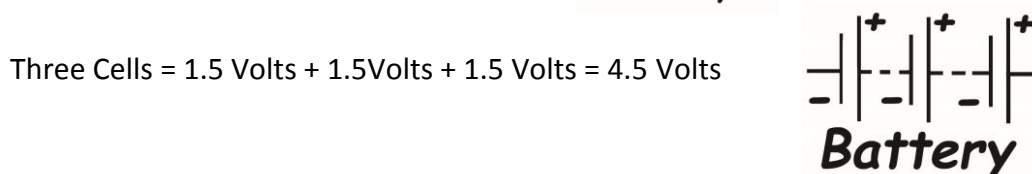
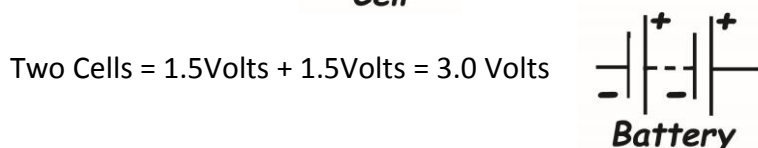
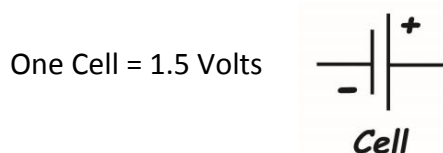

# BrightSparks 4kids - Electricity & Solar Energy Teaching Guide

---

Four Cells = 1.5Volts + 1.5 Volts + 1.5Volts + 1.5 Volts = 6.0 Volts

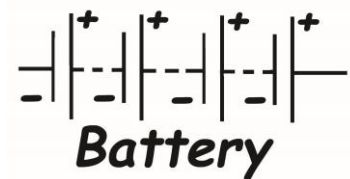

**Never link more than four battery cells together in a single circuit as damage may occur to the other components.**



**Bulb**

The light/lamp or Bulb module converts electrical energy into light. It contains a very thin coil of wire called a filament. When an electric current is passed through the coil heats up and produces light. The more electrical energy passing through it the more light is produced. The Bulb used in this kit is a low voltage miniature MES type and its rating can be visible on the metal casing. The Bulb is most commonly used in torches and household lighting around your home. It can be directly connected to the battery, operated with any switching module or used with the Variable Resistor Module to create a simple dimmer switch circuit. Supplied bulb Rating 3.8 Volts 70mA.

**Tip:** Look closely at the bulb can you see the filament inside?



**Care must be taken when handling glass bulbs as they are fragile components and may damage easily.**



**Buzzer**

The Buzzer module converts electrical energy into sound. It emits an audible tone when connected into a circuit. It is polarity sensitive and must be connected with the correct polarity (+/-) in order to operate. Changing the level of input Voltage produces different sound level outputs. The Buzzer is commonly used in cookers, microwave ovens and alarm clocks. Rated at 1.5V – 6Volts.

# BrightSparks 4kids - Electricity & Solar Energy Teaching Guide

---



## **Motor**

The Motor module converts electrical energy into motion. Its propeller rotates at a safe speed. The direction and speed of the rotation depends upon the polarity of the connection to the battery module. A motor is commonly found in a fan or a washing machine. This low inertia motor is ideal for Solar Projects as it has a very low starting current. The module can be connected directly to the battery or operated with any switching module. Alternatively use in conjunction with the Variable Module to create a speed control. Try connecting the red & black leads the other way around. What has happened to the rotation of the propeller? Ratings are 1.5V -12VDC max, 1540 RPM @ 2V.



## **Switch open**

The Switch module enables you to 'Open or Close' a circuit. This type of switch is commonly used as a household light switch or kettle. It has a sturdy 'On' or 'Off' toggle action with its down position as it's 'On' or closed state and 'UP' position as it's 'OFF' or open state.



## **Push Switch**

The Push Switch module enables you to momentarily 'Open or Close' a circuit with the push of a button. When pressed the Push Switch Module 'Closes' the circuit and when not pressed 'Opens' the circuit. This type of switch is commonly used in household doorbells, car horns and game controllers etc.



## **Magnetic Switch**

The Magnetic Switch module is also known as a Reed Switch. This has a pair of contacts which operate when a magnet is passed over them. The contacts close as the magnet is present and open once the magnet is moved away. This type of switch can be found in many security alarm systems as it needs no physical contact to operate. The Magnetic Switch Module can be used in various circuit applications.

**Tip:** Look closely inside the glass tube can you see the contacts inside?



## **Two Pole Switch**

The Two Way Switch module, also known as a changeover switch is a special type of two way switch. Depending on it's up or down position it allows current to pass either one way or the other. It is commonly used in household wiring where one switch can control two separate parts of a lighting circuit but has many useful applications.



Resistor module. Resistors limit or restrict the amount of current flow in a circuit. Various fixed resistors are included in this range and are available in popular values. Each resistor has a specific value and rating which can be found on the back of each module. They can be used for example as a protection component restricting the amount of current to an L.E.D or limiting the amount of current in a Motor circuit.

Values are various. Ratings are 5% 3W Metal Oxide.

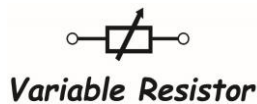

The Variable Resistor module also called a Potentiometer allows varying levels of electric current to flow through it depending on the position of the control knob. This module can be used as either a speed control for the Motor Module or as a dimmer switch for the Bulb Module. For best results use at least two Battery Cells (3 Volts). Values and ratings can be found on the rear of each module.



The Thermistor module changes its resistance according to the ambient temperature, at low temperatures the resistance is high, as the temperature rises the device becomes less resistive allowing more current to flow through it. It is commonly used in cookers, kettles and heating systems. This NTC Disc thermistor has a nominal resistance of 5K ohms.

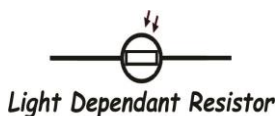

The Light Dependant Resistor module changes its resistance according to the amount of light that falls on its window. The more light the device receives the less resistive the device becomes allowing more current to flow through it. Uses are commonly found in automatic street lighting, intelligent car headlights and modern cameras. Dark resistance is 1M ohms.

## **The Flashing L.E.D**

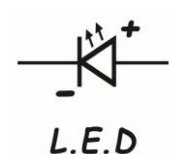

The Flashing L.E.D module produces a red flashing light and can be used as a visual indicator to add to your circuit. It is polarity sensitive and must be connected the correct way around in the circuit to operate. This module has an internal resistor for protection and requires a minimum of two battery modules to operate.

## **Red L.E.D Module**

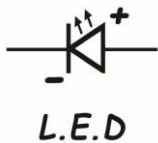

The Red L.E.D module produces a red light and can be used as a visual indicator or part of a traffic light circuit. It is polarity sensitive and must be connected the correct way around in the circuit to operate. This module has an internal resistor for protection and requires a minimum of two battery modules to operate.

## **Amber L.E.D Module**

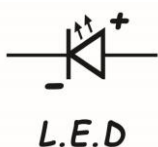

The Amber L.E.D module produces an amber light and can be used as a visual indicator or part of a traffic light circuit. It is polarity sensitive and must be connected the correct way around in the circuit to operate. This module has an internal resistor for protection and requires a minimum of two battery modules to operate.

## **Green L.E.D Module**

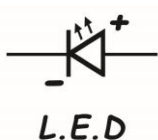

The Green L.E.D module produces a green light and can be used as a visual indicator or part of a traffic light circuit. It is also polarity sensitive and must be connected the correct way around in the circuit to operate. This module has an internal resistor for protection and requires a minimum of two battery modules to operate.

## **White L.E.D Module**

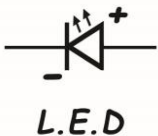

The White L.E.D module produces a white light and can be used as a visual indicator or torch circuit. It is polarity sensitive and must be connected the correct way around in the circuit to operate. This module has an internal resistor for protection and requires a minimum of two battery modules to operate.

## **Rainbow L.E.D Module**

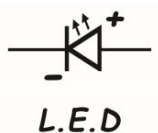

The Rainbow L.E.D module produces a rainbow effect of light and can be used as a visual indicator. These can be seen in children's night time lighting, often known as mood lighting. It is polarity sensitive and must be connected the correct way around in the circuit to operate. This module has an internal resistor for protection and requires a minimum of two battery modules to operate.

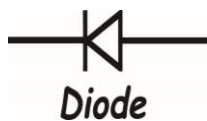

The Diode module can be used in advanced circuit design. It allows current to flow in only one direction. The Diode can be used, for example, as a blocking diode for the Solar Cell to stop accidental discharge whilst charging a battery, or as a polarity protection component if the battery terminals are accidentally reversed in a polarised component or circuit.

Type 1N5401 3A 100V Silastic Rectifier



The Solar Cell (or photovoltaic cell) module converts sunlight into electrical energy. Its uses are vast including calculators, mobile phone chargers, traffic lights, road safety signs, household and commercial uses and even in space! In good sunshine a small cell can produce enough power to directly power a Motor or Buzzer Module. As the output power is low compared to a battery, the Solar Cells are often linked together to produce more electrical energy. Please see page 27 for more details.



The Extra Component module is a universal component holder that can be used as a development tool by inserting different components into the spring connectors. For example, quickly connecting an external component to your circuit or adding components in parallel to combine their values. The Component Module offers a quick and easy way to develop your circuit.

### **Connecting leads**

The connecting leads supplied are easy to use and terminated with 4mm plug and socket style connectors at each end. They are 50cm in length and are stackable to create more complex circuits enabling easy hook up of parallel circuits or monitoring of voltage and current.

### **Crocodile adaptor clips**

The Crocodile adaptor's included in the kit provide an excellent way to test different materials to see if they do or do not conduct electricity. Simply connect a clip to each end of a connecting lead and attach your chosen material to test. Please see page 21 for more details.



## **Introducing Electrical Circuits**

### **What is a Circuit?**

We all use electronic devices in our everyday life. To work properly each device uses a special type of map called a 'circuit'. All circuits need the following key components to work, a power source, various components such as switches and motors and a way of connecting each component together (e.g. circuit board or wires).

**Think-** How many times you use different electronic devices everyday?

### **Definitions of terms**

#### **Voltage**

Voltage is an electric force; just as water needs pressure to flow a voltage requires current to operate around a circuit.

#### **Current**

Current is electricity in motion. It is a measurement of electrons that are moving through a material. Current is the amount of electrons flowing through a wire or can be described as the amount of water flowing through a hose in a given time. A circuit needs a complete path for electrical current to flow. This includes the voltage source.

#### **Resistance**

**Resistance** is found in electrical components. The amount of resistance reflects how much current and voltage are used to operate the component. Resistance can be likened to obstructing the flow of water in a hose e.g. placing a foot on a hose will reduce the water flow, pressing lightly would be a small amount of resistance and pressing more firmly would be a large amount of resistance.

**Conclusion-** Electricity can only travel around a circuit that has a complete path. That means the circuit has no gaps.

# BrightSparks 4kids - Electricity & Solar Energy Teaching Guide

The simple circuit example below shows a single battery cell connected to a bulb. The current flow begins at the (+) positive terminal of the battery and flows through the bulb then back to the battery at the (-) negative terminal of the battery. This completes a full circuit.

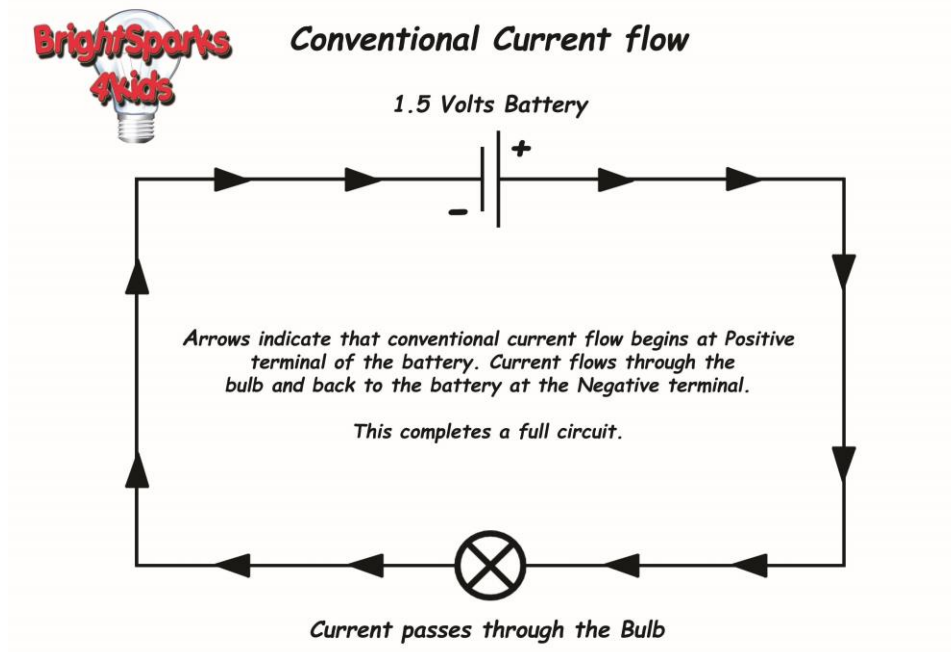

## Building Simple Circuits

Using the correct modules from your kit construct the following circuits.

### Activity 1 - Construct the following circuit

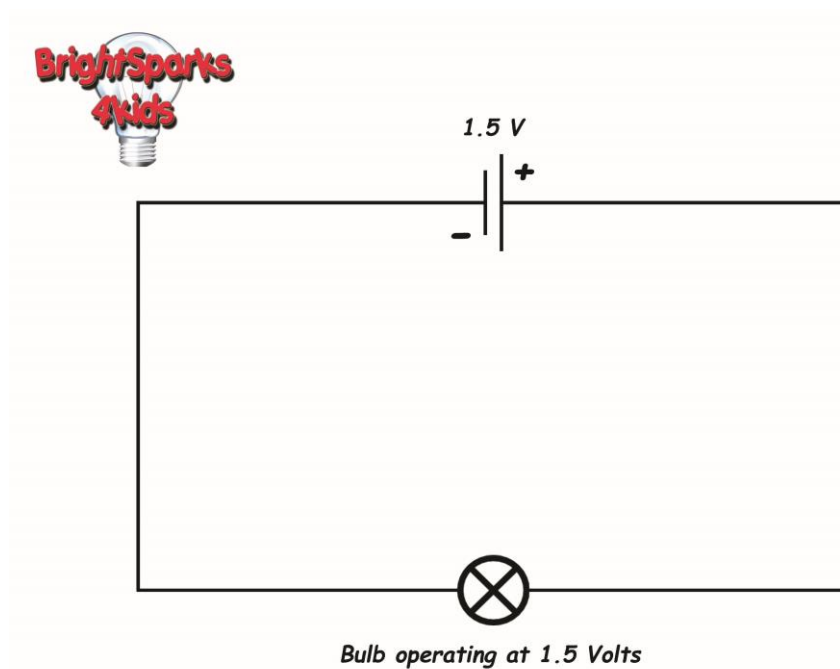

## Activity 2 - Construct the following circuit

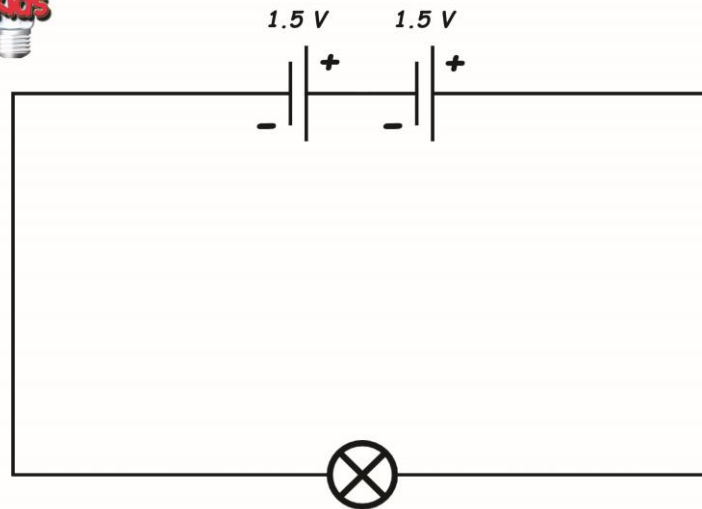

*Bulb operating at 3 Volts*

## Activity 3 - Construct the following circuit

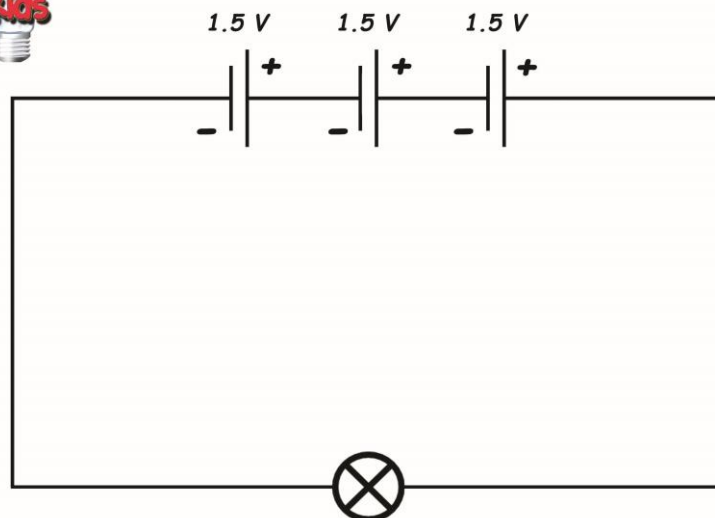

*Bulb operating at 4.5 Volts*

## Activity 4 - Construct the following circuit

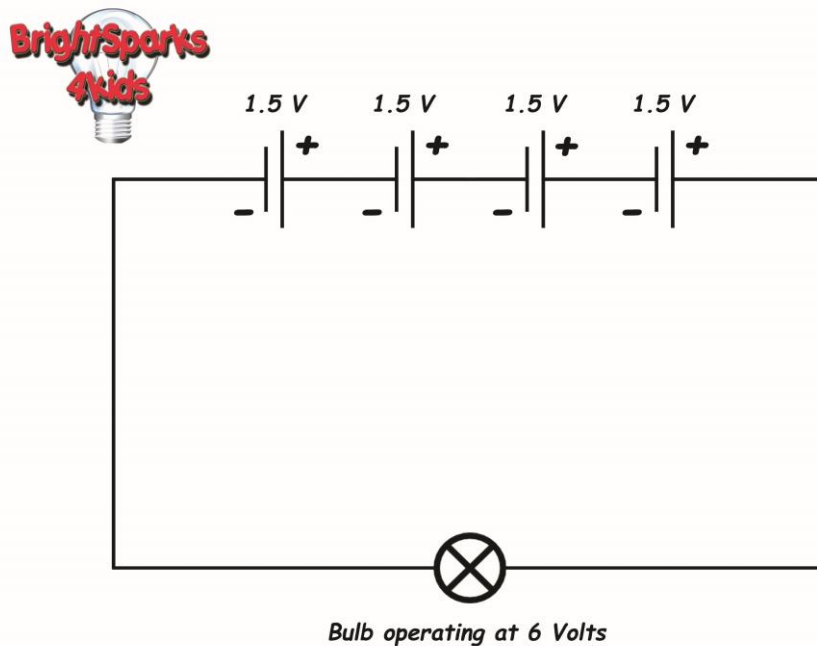

**Conclusion-** You should have noticed that by using only one battery in the first example, the bulb was not very bright. Therefore each time you added a battery you produced more power. The more power produced, the brighter the bulb became.

## Developing Circuits

Now you are familiar with simple circuit building we can look at adding more components to control your circuit. Construct the following circuit and observe what happens when the Switch module is activated.

### Activity 5 – Construct the following circuit

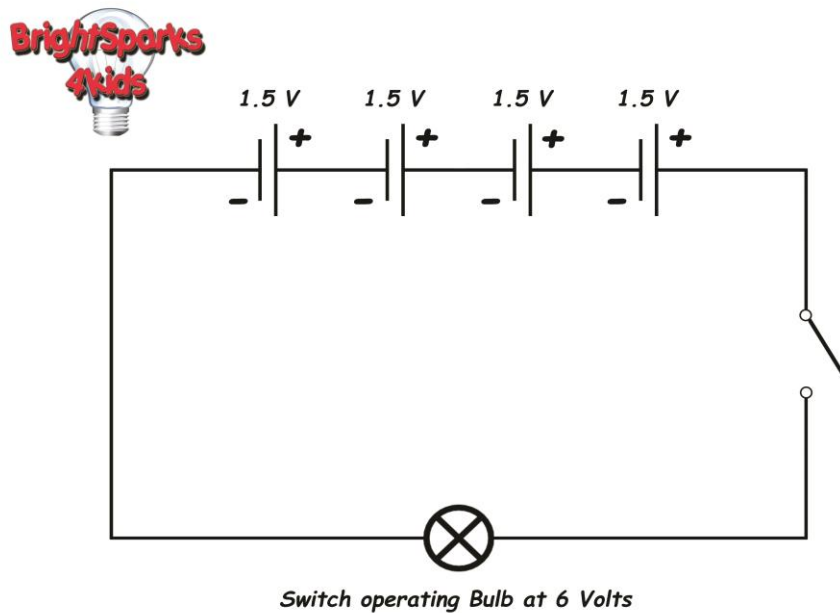

## Control

Look at **Activity 5** the switch acts as a control device for the circuit. When the switch is in the **UP** position it prevents current passing through it and when it is in the **DOWN** position it allows current to pass. This simple component can be found on many everyday items from boiling a kettle to turning on lights in your home.

**Think-** How many times do you use/operate something that has a switch in one day?

## **Activity 6 – Switch types used in everyday life**

Make a list of all the different types of switches that you use in a day.

<b>Switch type</b>	<b>Where would you find it used?</b>
Toggle switch	Used on a Kettle

Can you now pick an item from your list and find a similar type of switch in this kit? Explain why you chose this type of switch.

## Different types of control

**Note-** The following two circuits may require an additional Variable Resistor module (ST007) if not included in your kit.

Using a switch can control a device but what about if we need more control. For example, if you want to control the speed of a motor or the brightness of a bulb? If we used a switch we could only turn it 'ON' or 'OFF'.

However by using a Variable Resistor module we can now control the amount of current flowing in the circuit.

Construct the following circuit.

### Activity 7 – Construct the following circuit

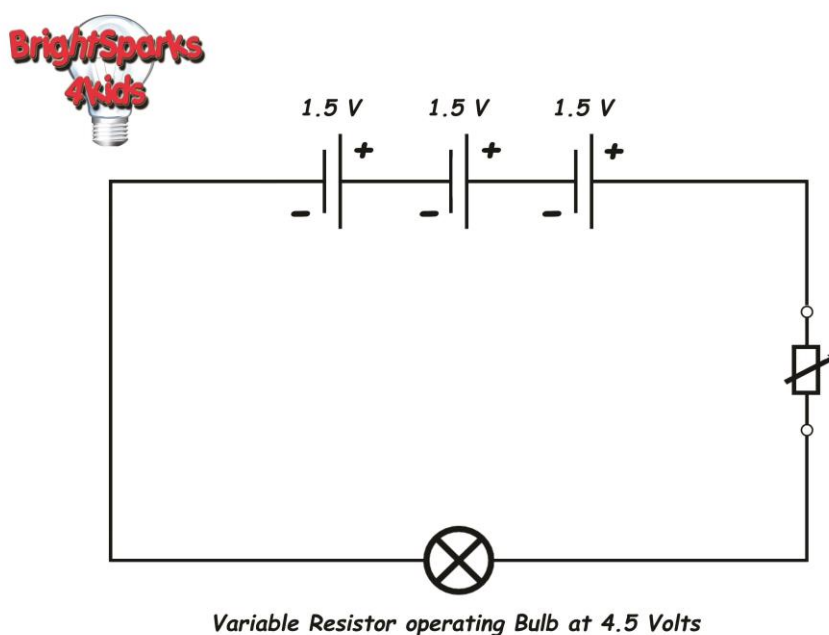

**Observe-** What happens when you turn the control knob on the Variable Resistor module in the above circuit?

**Conclusion-** As we altered the Variable Resistor module we increased or decreased the amount of resistance in the circuit. This allowed more or less current to flow through the bulb. The smaller the resistance, the more current flowed and the bulb was able to shine brighter.

## Activity 8 - Construct the following circuit

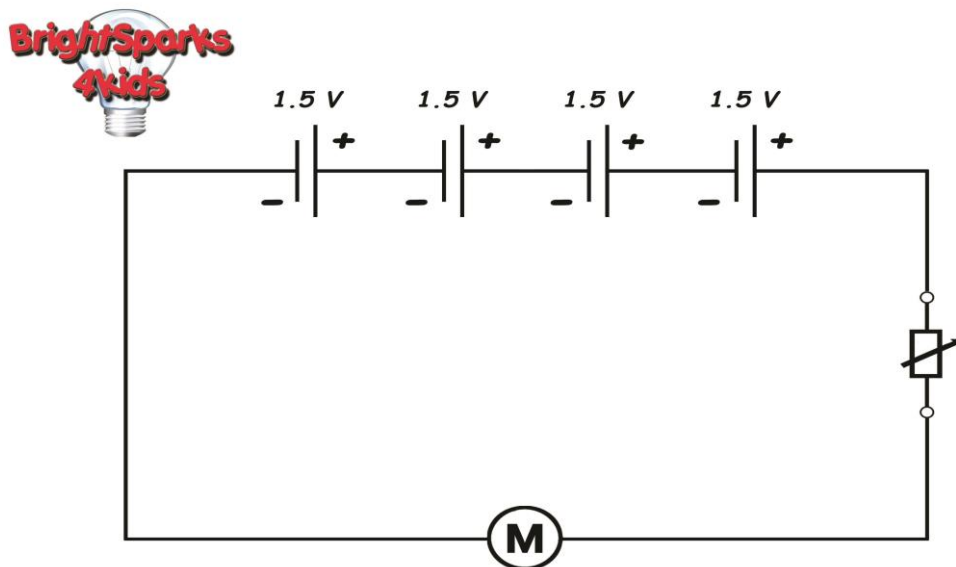

*Variable Resistor operating Motor at 6 Volts*

**Observe-** What happens when you turn the control knob of the Variable Resistor module in the above circuit?

**Conclusion-** As we altered the Variable Resistor module we increased or decreased the amount of resistance in the circuit. This allowed more or less current to flow through the motor. The smaller the resistance the more current flowed and the motor was able to rotate faster.



## Series and Parallel Circuits

There are two types of circuit. They are either 'series circuits' or 'parallel circuits'.

**Note-** It may be necessary to change the Bulbs to 6Volt 100mA type in the following examples.

### Series Circuits

Series circuits have only one path for current to flow to complete the circuit. Current must flow through every component to complete its path.

**Example 5 (figure 1)** shows two bulbs connected in series in a circuit.

### Activity 9 – Construct the following circuit

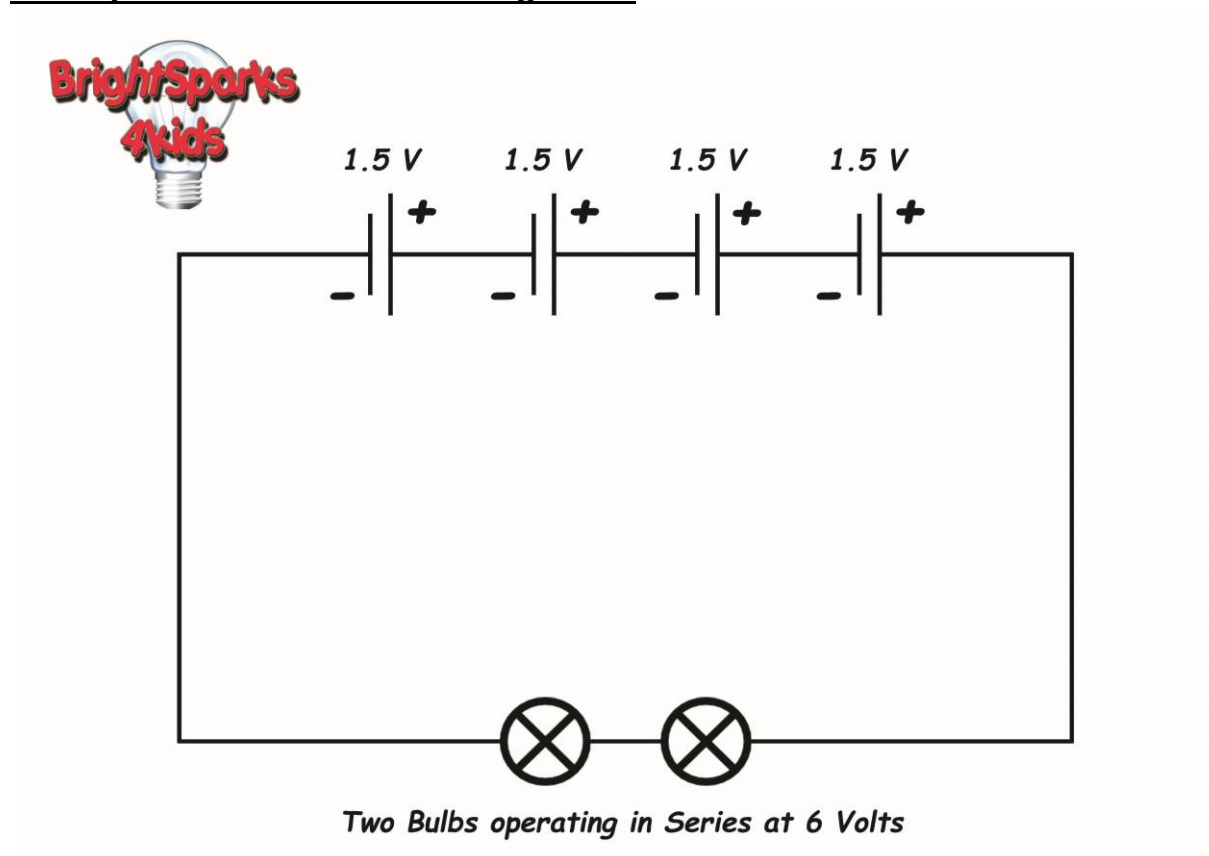

In this type of circuit all components must be connected to allow current to flow through them. Therefore if either bulb fails and becomes faulty, 'open circuit', the path is then incomplete and current will stop flowing around the circuit.

Notice the brightness of the two bulbs in relationship with only using one bulb as we connect them in series.

What is the difference when using more bulbs in series?

## BrightSparks 4kids - Electricity & Solar Energy Teaching Guide

**Try this-** Slowly unscrew one bulb from the bulb housing; this will simulate a failed component. What are the results?

***Remember to carefully replace the bulb back after!***

### Parallel Circuits

Parallel circuits have many paths for current to flow to complete the circuit. Current flows through each component directly and is therefore not affected by the other components.

The below circuit shows two bulbs connected in a parallel circuit.

### Activity 10 – Construct the following circuit

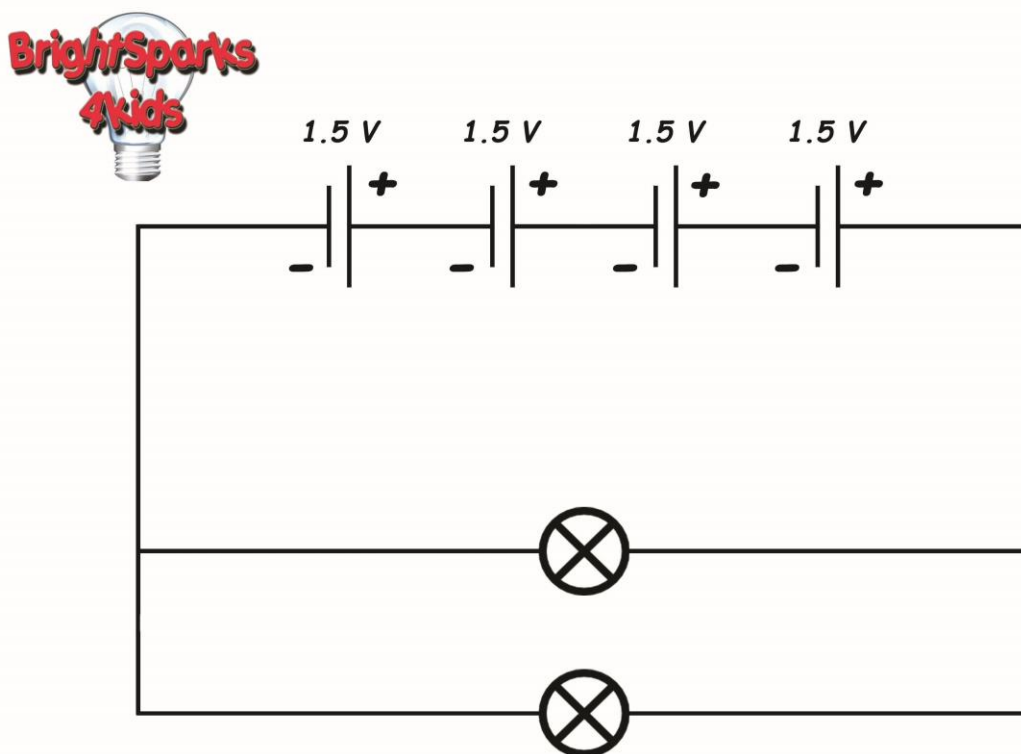

*Two Bulbs operating in Parallel at 6 Volts*

In this type of circuit all components are connected separately and each have a direct connection to the battery. Therefore if either bulb fails and becomes faulty, current will continue to flow through the rest of the working components in the circuit. This type of circuit is commonly found in domestic house wiring.

Notice the brightness of the bulbs as we connect them in parallel. They should be the same or only slightly dimmer (due to safety restrictions in the battery module).

# BrightSparks 4kids - Electricity & Solar Energy Teaching Guide

**Try this-** Slowly unscrew one bulb from its housing. This again will simulate a failed component. What are the results this time in a Parallel Circuit?

## Activity 11 – Experiment with other modules

Now experiment with other modules in the range with series and parallel connections to see the effects and combinations that can be produced. Refer to the Example Circuits CD-ROM for some ideas.

Produce circuits that are used in everyday life that use lights, switches, sound and motion to operate or provide warning.

## Advanced Circuits

By using what we have learned so far we should be able to produce more complex circuits by combining different modules in this range.

## Activity 12 - Construct the following circuit

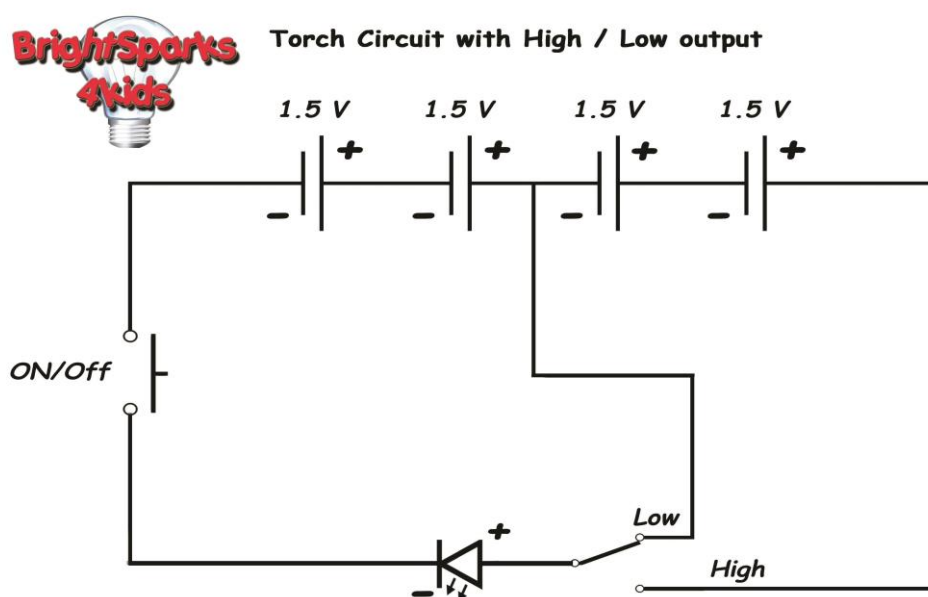

# BrightSparks 4kids - Electricity & Solar Energy Teaching Guide

## Activity 13 – Name each component module

Can you name all 7 modules and describe what function they do in the above circuit diagram?

Component name	Function
Battery 1	To supply power of 1.5 Volts to the circuit

## Activity 14 – Construct the following circuit

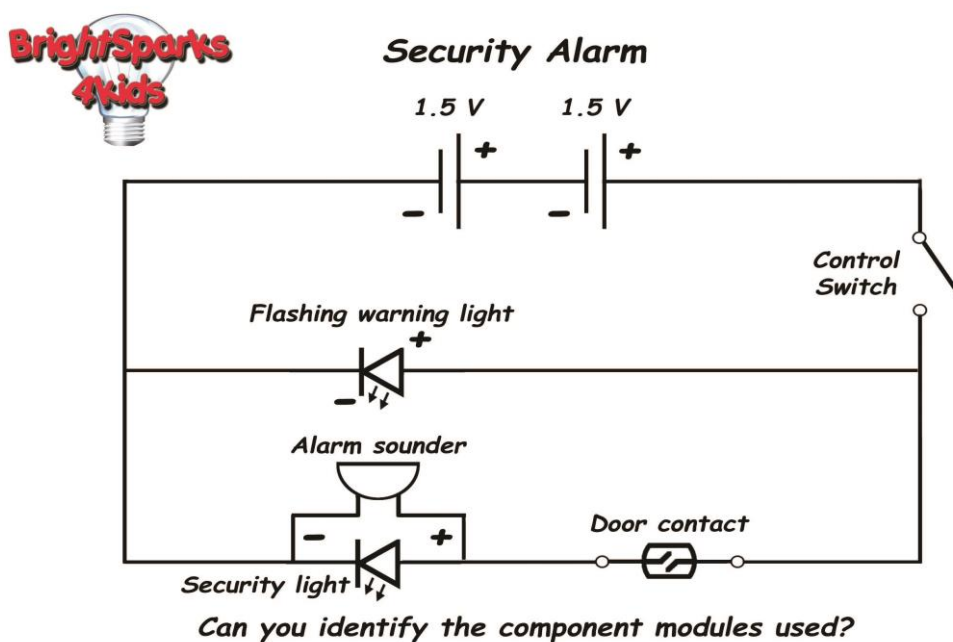

## Activity 15 – More complex circuits

Can you draw and design a more complex circuit? This time show how you could add more door contacts to simulate a full house burglar alarm system.

## Conductors or Insulators?

We know that a working circuit needs to have a voltage source and a complete path in order for current to flow. This path is connected by conductors.

Construct the simple circuit below to test different materials. Connect one end of a lead to the battery and the other end with a crocodile adaptor clip. Connect another lead from one end of a Bulb or L.E.D and the other to another crocodile adaptor clip. Connect different material types to each end of the crocodile clips. If the bulb lights up they are **Conductors** and if the bulb does not they are **Insulators**.

## Activity 16 – Construct the following circuit

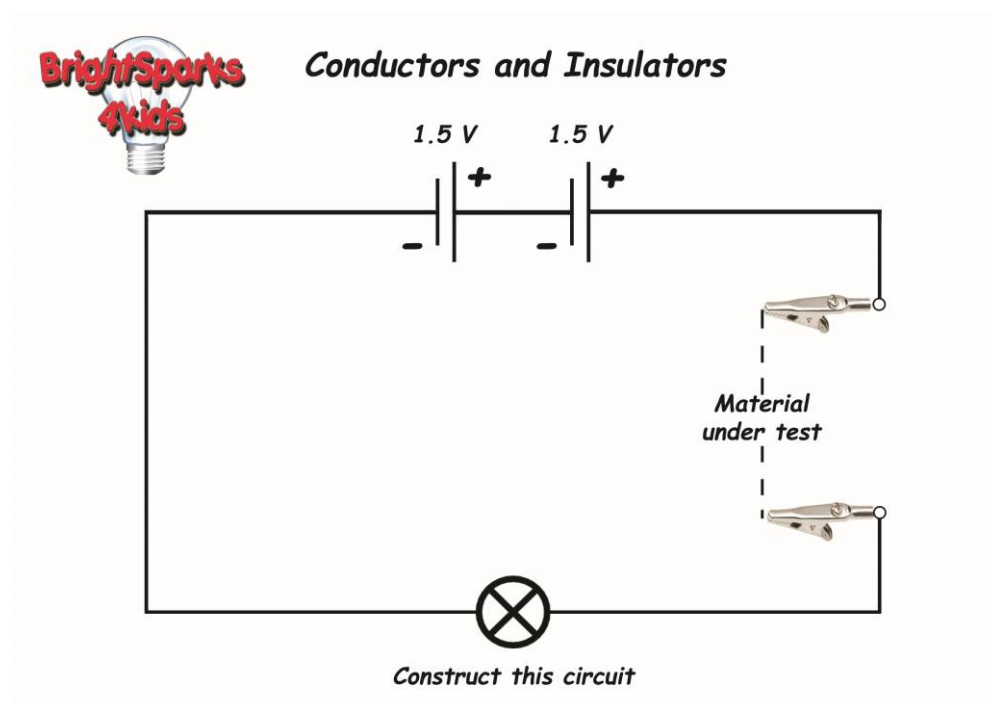

Good conductors are made of the following materials:

- Copper
- Steel
- Gold
- Aluminium
- Brass

Insulators are the opposite of conductors as they **Do Not** allow current to flow across them.

# **BrightSparks 4kids - Electricity & Solar Energy Teaching Guide**

Good insulators are made from the following materials:

- Rubber
- Paper
- String
- Plastic
- Wood

## **Activity 17 – Results table and using other materials**

Try using other materials and construct a table of your results.

<b><u>Material tested</u></b>	<b><u>Conductor</u></b>	<b><u>Insulator</u></b>

## Measurement with a digital multimeter

Sometimes we need to know a little more about our circuits and need to measure the Voltage, Current or Resistance. For example, we may want to measure our battery voltage or how much current our Bulb module takes. We could even measure the resistance of the Light Dependant Resistor module (LDR) on a sunny day.

### Measuring Voltage



Multimeter set to read DC Volts

Voltage is measured in Volts abbreviated as V. Measurement of volts is often done by a voltmeter or digital multimeter and set to read volts.

Connections are made in parallel across the component to be measured.

Picture for illustration only

### Activity 18- Construct the following circuit

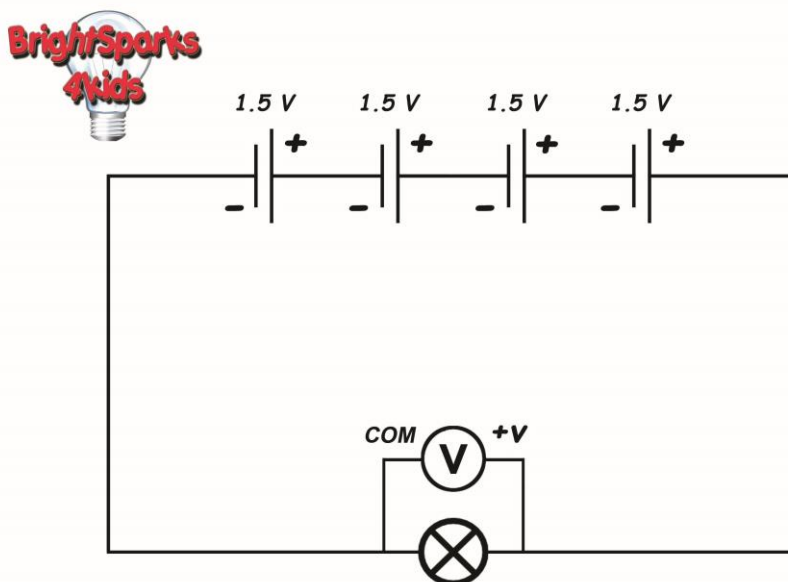

Measuring the Voltage across a Bulb operating at 6 Volts

To measure the voltage across a Bulb module, set up the multimeter as shown in example 10 (figure1). You should typically observe a reading of 6.0 Volts on the multimeter display.

## Measuring Current

Current is measured in amps and is abbreviated as A or in mA (milliamps) in the case of this kit.

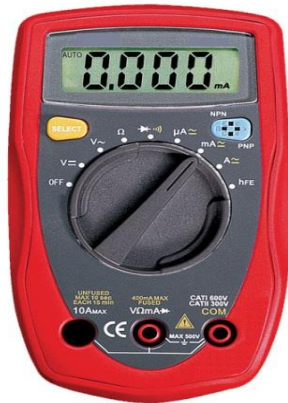

Multimeter set to read mA Current

Current is measured by an ammeter or often by a digital multimeter, which has a current setting. Adjust the dial and set it to read DC current. In some cases this may also require a lead change from the +V (red socket) to the mA socket depending on your choice of multimeter. Connections are made in series with the component to be measured.

Picture for illustration only

## Activity 19 – Construct the following circuit

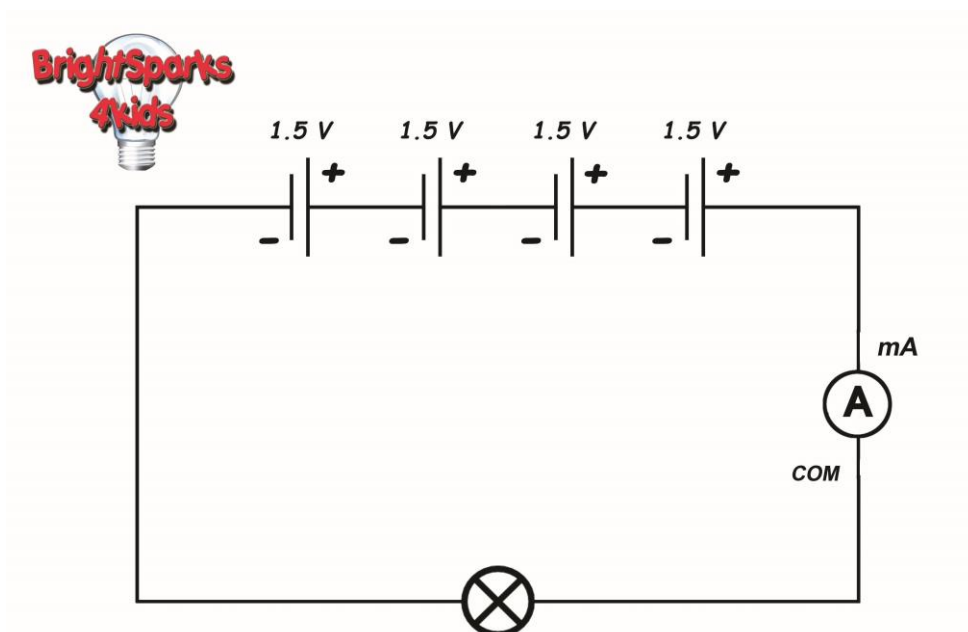

Measuring the Current of a Bulb Circuit operating at 6 Volts

To measure the current of the bulb module, set up the multimeter as shown Example 11 (figure 1). You should typically observe a reading of the bulbs individual rating (the standard bulb supplied in this kit is 70mA) on the multimeter display.

**Try this-** Unscrew the bulb and you will see that the bulb will go out and the current will fall to zero on the display.



## Measuring Resistance

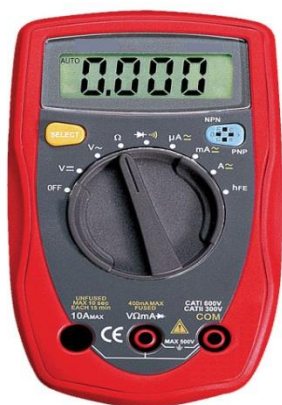

*Multimeter set to read Resistance*

Resistance is measured in ohms and abbreviated as R or  $\Omega$ .

If we wish to measure, for example, the resistance of the Light Dependant Resistor Module (LDR) in bright sunlight or the temperature of the Thermistor Module on a warm day we would use a digital multimeter set to read  $\Omega$  Ohms.

**Picture for illustration only**

**TIP-** Many other electrical components can be checked out with a simple resistance check! These include Bulbs, Switches, fuses and many more.

The important thing to remember about measuring resistance is it is done with the component NOT connected to any power source (battery) or any other part of the circuit. This is because the circuit already has resistance in the other circuit components which will directly affect the measurements obtained.

Connections are made in parallel across the component to be measured.

## Activity 20 - Measuring an LDR

### Multimeter set to Resistance

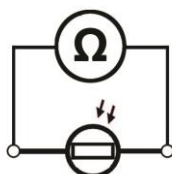

*Light Dependant Resistor*

To measure the resistance of the Light Dependant Resistor, set up the multimeter as shown in Example 12 (figure 1). Put your finger or a piece of card over the round window of the LDR. You should typically observe a reading of  $1M\Omega$  on the multimeter display. Now release your finger and you should observe the reading reduce. Measure the resistance in a dimly lit area then measure it again in a well-lit area. You can see that the more light the less resistance the component has.

**TIP-** When measuring resistance there is no polarity therefore leads can be connected either way around the component.

## The Thermistor module

The Thermistor Module changes its resistance according to the ambient temperature, at low temperatures the resistance is high, as the temperature rises the device becomes less resistive allowing more current to flow through it. It is commonly used in cookers, kettles and heating systems.



## Activity 21 - Measuring a Thermistor

Connect a digital multimeter to each terminal as shown. Set it to read resistance ( $\Omega$  or Ohms) you should observe around  $5K\Omega$  on the display.



**Try this-** Put a finger onto the body of the thermistor. You should be able to see the resistance change quite rapidly, either up or down depending on the temperature of your finger in relationship with the device.

To test this in circuit set up the following experiment as shown below. As we can see, the Flashing Led module is flashing but not very bright. This is already due to the ambient resistance of the thermistor in circuit. Try warming up the thermistor with a heat source, this works particularly well with a hair dryer. You should notice the Flashing Led is now considerably brighter as the internal resistance of the thermistor has now been reduced by heating. Typically down below  $1K$  Ohms.

Next allow the device to settle back to room temperature (this may take a few minutes) and this time apply a cold temperature to the device. This works particularly well with an ice pack from the freezer. Notice the Flashing LED getting considerably dimmer as the device gets colder and colder. In tests after approximately 1 minute the LED should be barely visible.

## Activity 22 - Construct the following circuit

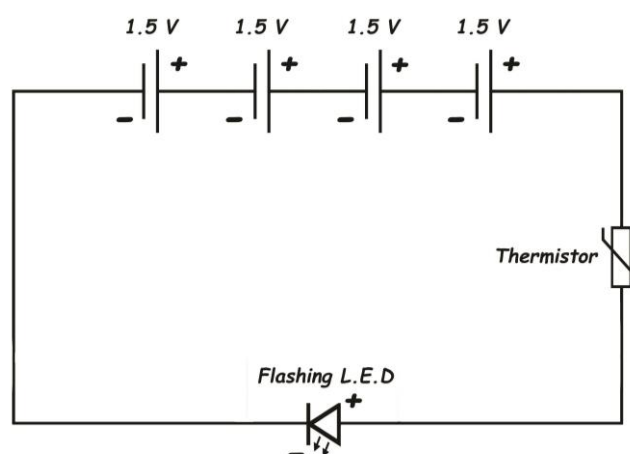

*Thermistor Temperature circuit with Flashing L.E.D at 6 Volts*

## Test yourself

### Circuit symbols

Can you name circuit symbols?







Can you fault find a simple circuit?

Can you design your own circuits?

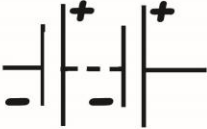
### Activity 23 - Can you name the correct circuit symbol?

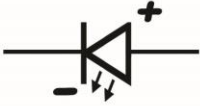
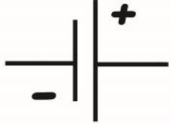
Fill in the blanks below and name all the circuit symbols.

 *Can you name these Circuit Symbols*

 _____	 _____	 _____
 _____	 _____	 _____
 _____	 _____	 _____

**Tip-** You will find each answer somewhere in this guide.

## Fault finding

Now that you are familiar with simple circuits could you find a fault and rectify the problem?

Look closely at the following circuit examples. Can you identify what is wrong with the each circuit and why they do not work correctly?

### Activity 24 – Construct the following circuit

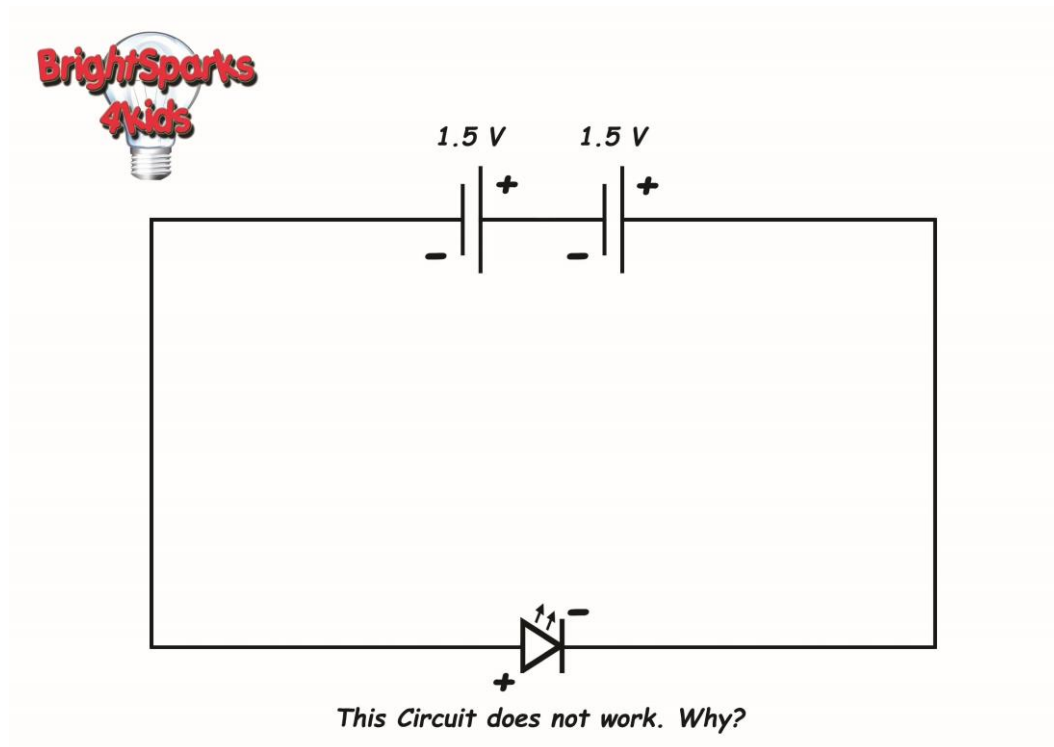

## Activity 25 - Construct the following circuit

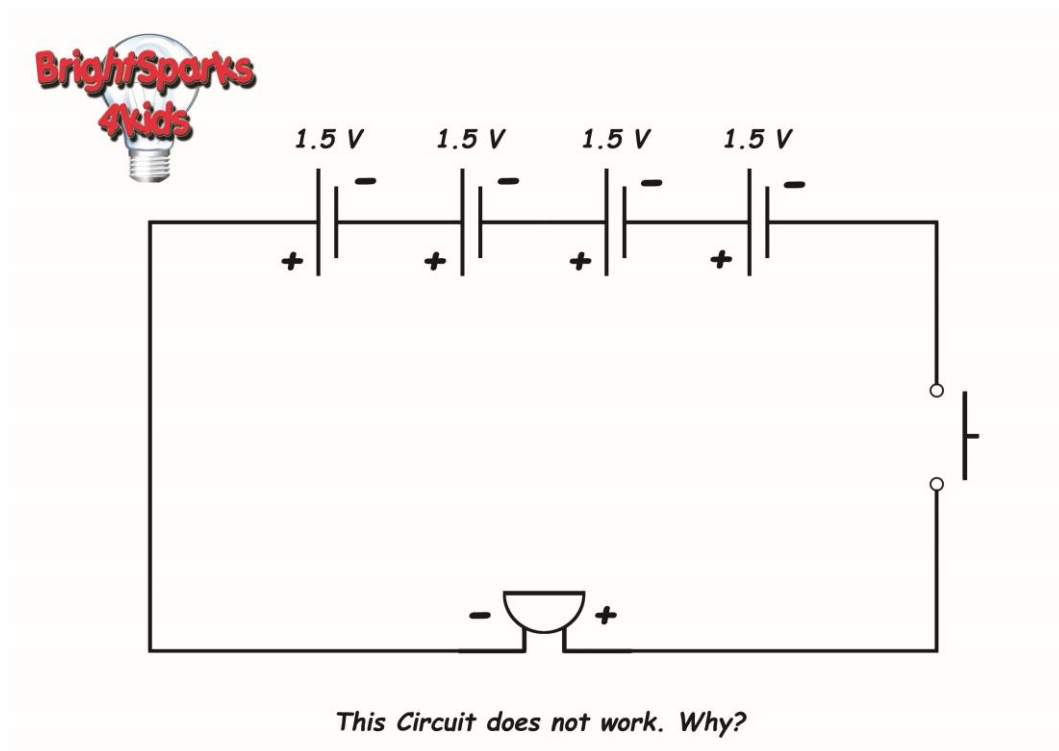

## Activity 26 - Construct the following circuit

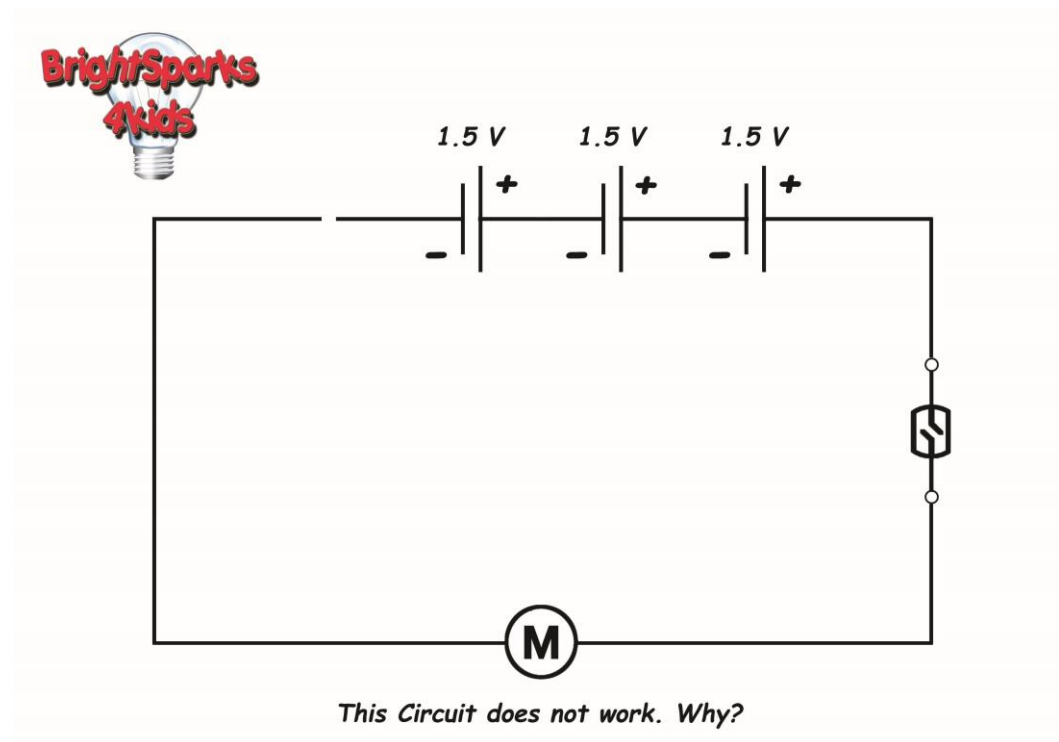

## Designing your own circuits

Can you design your own circuit? Think about what you have learned so far and add some relevant components to the following incomplete circuits.

### Activity 27 – Add a control and output device

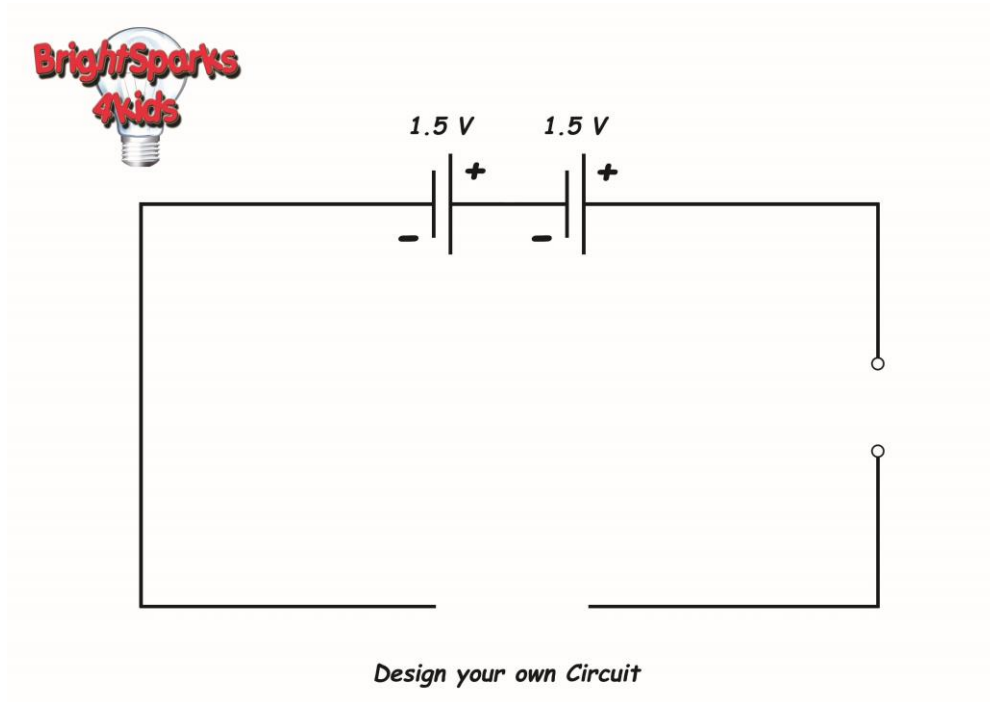

The diagram shows a rectangular circuit loop. At the top, two 1.5V batteries are connected in series. The first battery is on the left with its negative terminal (-) on the left and positive terminal (+) on the right. The second battery is on the right with its negative terminal (-) on the left and positive terminal (+) on the right. The circuit is incomplete on the right side, with two open terminals. In the top-left corner, there is a logo for 'BrightSparks 4kids' featuring a lightbulb.

*Design your own Circuit*

### Activity 28- Design your circuit from scratch

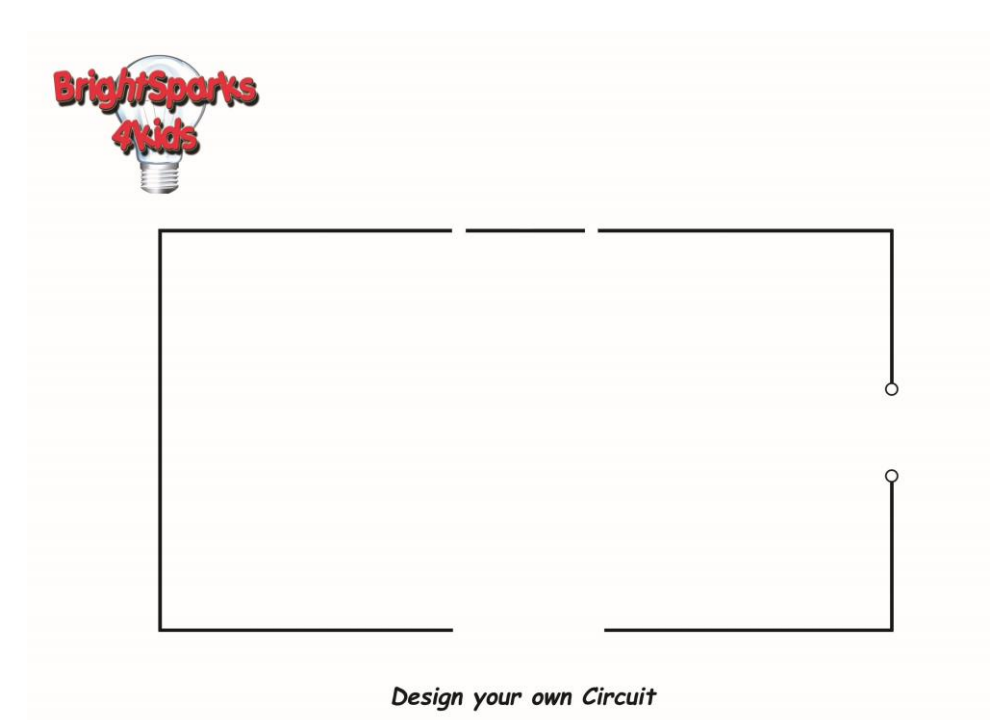

The diagram shows a rectangular circuit loop that is completely blank. On the right side, there are two open terminals. In the top-left corner, there is a logo for 'BrightSparks 4kids' featuring a lightbulb.

*Design your own Circuit*

**Activity 29 - Electricity Wordsearch**



**Electricity Wordsearch**

M O T O R B Y V J R  
X V N N C R U K N O  
M O G N E Z O L V T  
E G A T L O V I B A  
R O T C U D N O C L  
O A C I R C U I T U  
B C U R R E N T W S  
E I H C T I W S I N  
E N E R G Y C N R I  
R E Z Z U B L L E B

BATTERY  
BUZZER  
CURRENT

BELL  
CIRCUIT  
ENERGY

BULB  
CONDUCTOR  
INSULATOR

[www.brightsparks4kids.com](http://www.brightsparks4kids.com)

## Solar Energy Investigations Teaching Guide

### So what is Solar Energy?

Solar energy is power from the Sun, without it we cannot live. The main benefit of solar energy is that it does not produce any pollutants and is one of the cleanest sources of energy. It is also a renewable source of energy and requires low maintenance although initial set up costs can be expensive. However the downsides to solar energy are that they cannot be used at night, the amount of sunlight available depends on location, time of day, and time of year together with varying weather conditions.

### What are Solar cells?



Solar cells are devices that convert light energy directly into electrical energy.

### Solar cells in everyday life

Solar cells are a 'clean energy' that is not harmful to our planet. We can see solar cells being used in everyday life, from small handheld devices such as calculators to huge satellites in outer space! They are ideal where a traditional power cable source is not available such as a desert or ocean. They are also available in many different shapes and sizes to suit the individual application. Even flexible cells are now available that can be worn on clothing!

Examples of L.E.D lighting can be seen everywhere from traffic lights and street lights to modern day torches and bicycle lights. Compared to conventional light bulbs they only need a fraction of the energy to work.

Solar cells work best in direct sunshine without obstruction I.e. non-cloudy days.

Avoid using through a window especially windows that are coated or tinted as this reduces the cells efficiency. However results can still be achieved through glass even on cloudy days

**Note-** The following examples in this guide may require additional modules and equipment such as a multimeter, use of a 60W halogen lamp or the Advanced Electricity kit AEK-01, Advanced Electricity Kit PLUS. These products are available separately from our website for more details please go to [www.brightsparks4kids.com](http://www.brightsparks4kids.com)



## Activity 30 – Listing Solar Cell Applications

Can you make a list of different applications that use Solar Cells? (See page 40 for typical answers)

Solar Cell applications	What is it used for and why?

## Getting started

Each component in this range has been specifically designed to work well with the supplied solar cell and good results can easily be achieved outside on a sunny day or even indoors with the use of a 60 Watt halogen lamp or high powered halogen torch.



**Caution- Avoid looking directly into the Sun on hot sunny days as it may be harmful to your eyes.**

## Activity 31 - Connecting an output

Connect your solar cell to an L.E.D module (for best results use White L.E.D module ST011) using the test leads accordingly and face the cell towards the Sun. You should already see the L.E.D light up!

**Congratulations-** You have just successfully created your first solar powered circuit by using the Sun's free energy to convert light energy into electrical energy then back into light using the L.E.D.

(If you don't see the L.E.D light up, check your cell is facing the sun and you have connected everything up correctly ensuring voltage polarity)

# **BrightSparks 4kids - Electricity & Solar Energy Teaching Guide**

**Try this-** Try shading the cell with your hand or piece of card and see what happens to the level of light produced by the L.E.D? (See page 42 for more shading experiments)

Is it brighter or dimmer?

Can you already explain why?

## **Measuring the output of a Solar Cell**

So far we have learned that if we connect certain components directly to a cells output we can observe it's transferred light energy. However sometimes when designing Solar powered circuits we may need to measure, calculate and record our results accurately. The best method for this is to use a digital multimeter that has multiple features such as Voltage and current measuring capabilities.

## **Using Solar Cells indoors**

We cannot always guarantee the sun will shine when we want it to. However if we substitute a suitable 60W or higher halogen lamp for the sun we can still observe how cells react to different intensities of light.

### **Warning!**



**The following experiment uses a Halogen bulb. Care must be taken at ALL TIMES to avoid injury as the glass bulb gets extremely hot and can stay hot long after use.**

## **Activity 32 – Measuring a Cells output at different distances from the source**

To do this experiment you will need the following items:

Solar Cell module (ST025/ST028)

60W halogen lamp or high power rechargeable halogen torch

Digital Voltmeter or multimeter

Digital Ammeter or multimeter

# BrightSparks 4kids - Electricity & Solar Energy Teaching Guide

Connecting leads (Red + Black)

Measuring device i.e. ruler or tape measure capable of 40 Centimetres

Set up the experiment as detailed below with the lamp powered **OFF**.

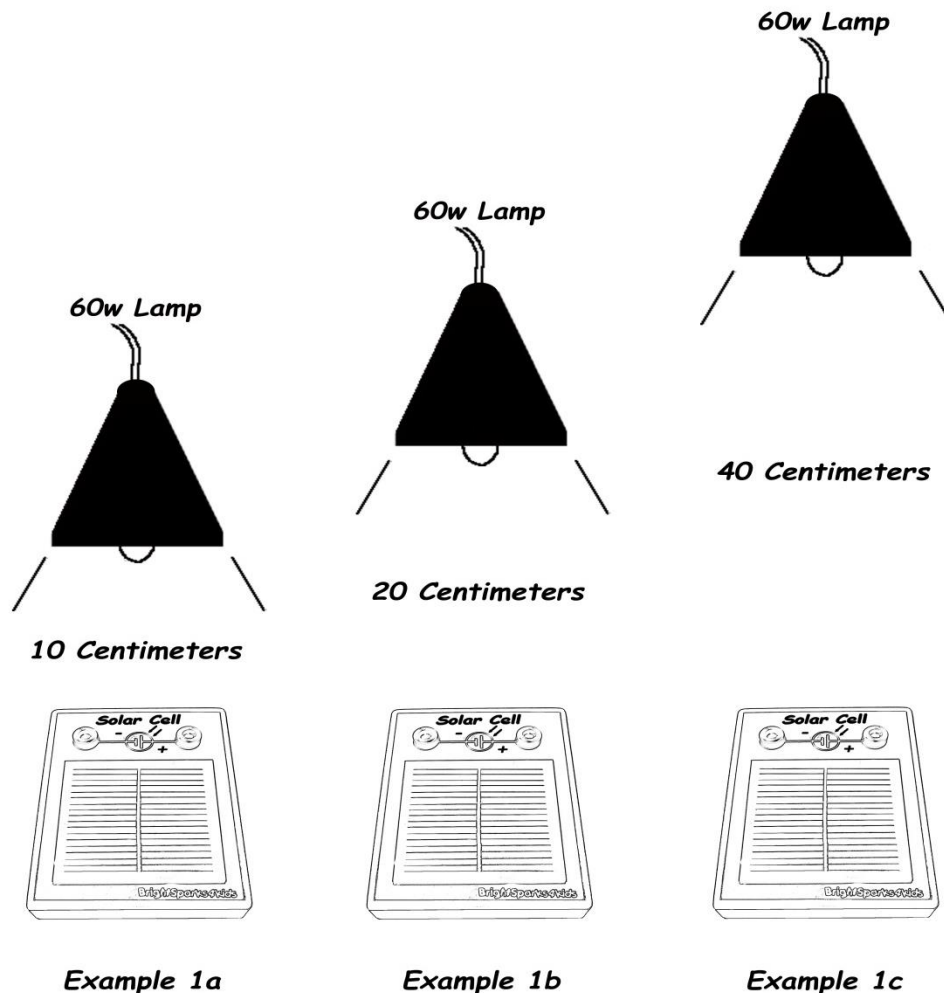

Using a ruler measure the distance from the cell to the halogen lamp as in example 1a. Try to position the halogen lamp directly above the cell so to achieve its maximum efficiency.

Connect a digital multimeter and set it to read DC voltage and connect the leads to the appropriate +/- terminals on the cell. Depending on your classroom lighting you may already be showing a small voltage on your multimeter. Turn **ON** the halogen lamp and you should see the voltage has significantly increased on the multimeter.

Use the table below to insert your first voltage reading in the appropriate column.

Leaving the lamp distance the same now change the digital multimeter to read DC current and insert its reading also in the appropriate column.

## **BrightSparks 4kids - Electricity & Solar Energy Teaching Guide**

Continue to follow each example increasing the distance from solar cell to the lamp each time. For safety please **remember to turn OFF** the halogen lamp each time you increase or decrease the distance and avoid touching the lamp.

**Due to the heat generated by a halogen lamp avoid going any closer than 10cms as it may harm the cells protective top layer**

All results are dependent on which solar cell you are using and light source. You can include your Solar cells model rating and light source in rating column below.

<b><u>Solar Cell rating =</u></b>		
<b><u>Light source rating =</u></b>		
<b><u>Lamp Distance</u></b>	<b><u>Voltage reading</u></b>	<b><u>Current reading</u></b>
<b><u>40 centimetres</u></b>		
<b><u>20 centimetres</u></b>		
<b><u>10 centimetres</u></b>		

**Conclusion-** You should see from your results table that the closer the lamp was to the cells surface the higher both readings were on the multimeter. This clearly shows that the more intense the light is to a cell the more power can be transferred from light energy to electrical energy. (See typical results on page xxx)

### **Activity 33 – Measuring a Cells output at different angles from the source**

Try altering the Cells angles to the light source and see what affect it has on your results. To do this set up a similar experiment as Activity 16 but with the Cell at various angles to the light source with one of the distances already measured and as before measure and record your results.

This can be done simply by using rigid cardboard and bending into shape to create angles from 0 to 45 degrees. As show below in the activity.

Alternatively and depending on your choice of Solar Cell module it may already have a tripod mount ST025 (tripod sold separately) if so simply attach the tripod to the rear of the cell and alter its alignment/angle to the light source and tighten the screw adjust. Try degrees such as 0, 25 & 45 degrees and see what effects this has on your results?

## Guide instructions for cardboard 45 degrees alignment jig

For best results use a medium to strong ply cardboard roughly A4 size and sufficiently strong enough to hold the Solar Cell module securely. Then mark and fold out two equal bends at 85cms. Lastly fold over the last section (120 cms) and use Sellotape to attach. To construct the 25 degree jig follow the same method again with an A4 piece of card but this time use the following guide measurements, A= 53 cms, B = 114 cms, C = 125 cms. For more precise results and other angles please uses a protractor.

### Example of a 45 degrees alignment Jig

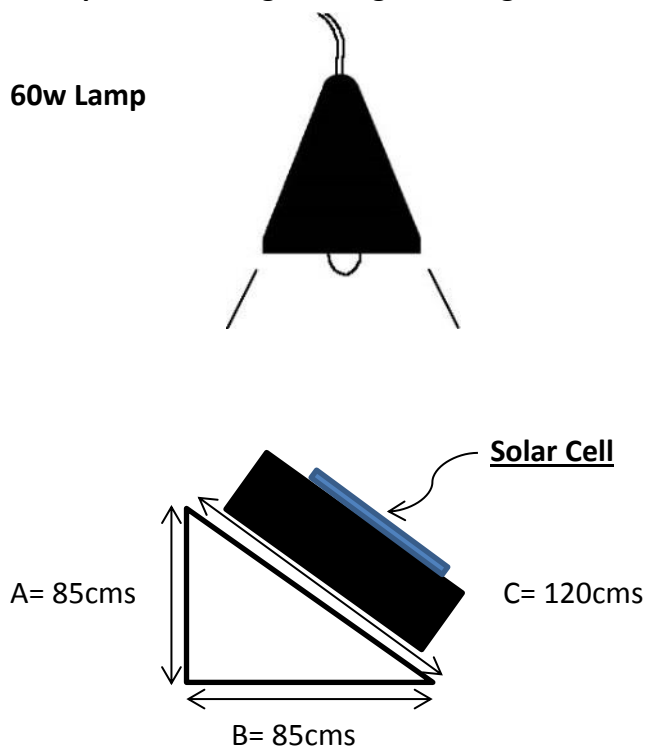

Record your results on the below table

<u>Solar Cell rating =</u>		
<u>Light source rating =</u>		
<u>Lamp Distance =</u>	<u>Voltage reading</u>	<u>Current reading</u>
<u>0 Degrees- (Flat)</u>		
<u>25 Degrees</u>		
<u>45 Degrees</u>		

# **BrightSparks 4kids - Electricity & Solar Energy Teaching Guide**

Are your results any different as the Cells angle changes from the light source?

Can you explain why?

## **Storing energy**

We have learned so far that solar cells convert light energy into electrical energy. But what happens after the sun goes down? Do solar cells still work at night? In fact a solar cell does not have any capacity to store this useful energy itself they merely convert the energy.

## **So how can we store the energy produced by the cell?**

If we wanted to store the energy produced by a Solar cell we can use either rechargeable batteries/packs or a super capacitor. In comparison charging re-chargeable batteries usually takes several hours although storage capacities are usually larger whereas charging a super capacitor can only take a few minutes. The individual storage capacity of a 'Super cap' is usually smaller however surprisingly a 10F capacitor can still power up a small device like an L.E.D for hours!

## **Different cell types**

For our kit we have included a Polycrystalline Silicon cell (PV) although there are many different types of solar cells now available. These include **Monocrystalline, Polycrystalline** and **Amorphous**. Each uses a slightly different type of manufacturing process but all have the same intended use.

## **Cell power ratings**

The power of a cell is measured in Watts (W) and is derived from its Voltage multiplied by its current. For us to design circuits around solar cells we first must know a little more about each cells capability. Most solar cells have their operating ratings indicated somewhere on them. For our example we will discuss the specifications of a cell with a Voltage of 1.5Volts and the current of 250mA. This means that on a good sunny day, under optimum conditions, the cell can potentially produce a nominal voltage of 1.5Volts & a nominal current of 250mA.

Therefore its nominal power rating (measured in Watts) is stated as its Pmax and is calculated as follows-

Voltage x Current = Power

Abbreviated into  $V \times I = P$

So  $1.5 \times 0.250 = 0.375W$ . Therefore our example cell has a (Pmax) power output of 0.375W

## But what if we needed more power?

If we use multiple solar cells connected to multiple battery cells we can store lots more energy. Some batteries have a large enough storage capacity to even power an electric car!

Depending on your circuit requirements and power needs, solar cells can be connected singularly for use with low power components such as the Buzzer module or the Motor module. Or if more power is required, cells can be connected together in series or parallel to combine their power (similar to batteries). These multiples of cells are often called Solar Panels. The 'Panel' being collective name for many cells connected together to give a larger power output.

You can see from the below examples that in series configuration the voltage increases (ideal for use with the L.E.D modules as they require above 2.3Volts to operate) and the current stays the same and a parallel configuration the voltage stays the same but the current increases (ideal for using higher power devices).

## Example of solar cells in series increasing Voltage

One Solar Cell = 1.5 Volts @250mA (Example Product No-ST024)

Two Solar Cells = 1.5 Volts + 1.5 Volts = 3.0 Volts @250mA

## Activity 34 – Construct the following circuit

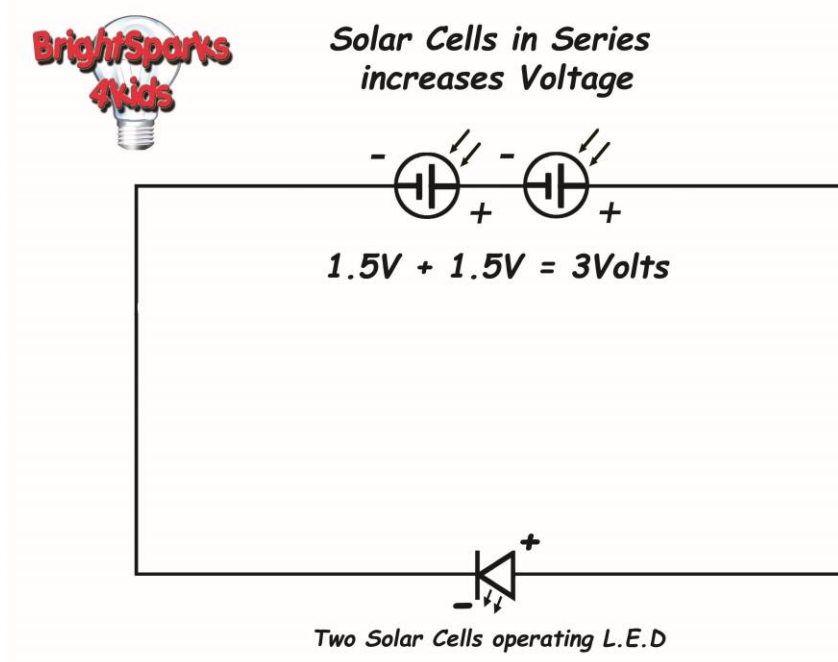

## BrightSparks 4kids - Electricity & Solar Energy Teaching Guide

Measure firstly the Voltage of a single cell then try adding more cells in series and measure the total voltage combined with a Voltmeter. What happens to the voltage each time a cell is added? (avoid shading any cells in your tests)

### Example of solar cells in parallel increasing current

One Solar Cell= 1.5 Volts @250mA

Two Solar Cells = 250mA + 250mA = 1.5 Volts @500mA

### Activity 35 – Construct the following circuit

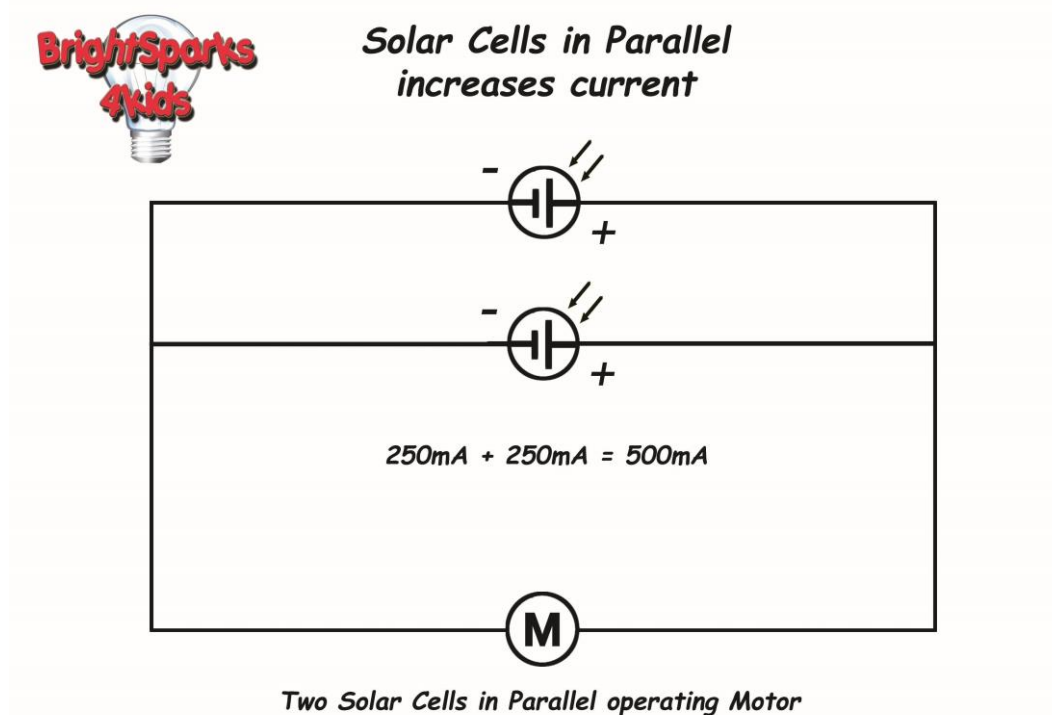

Measure the current firstly of a single cell then try adding more cells in parallel and measure the total current with an ammeter. What happens to the current each time a cell is added? (avoid shading any cells in your tests)

**TIP-** Remember to measure the current in series with the circuit see page 24.

### **Warning!**



The following experiment uses a Halogen bulb. Care must be taken at ALL TIMES to avoid injury as the glass bulb gets extremely hot and can stay hot long after use.



## **Activity 36 - Cell size & exposed area to light**

To do this experiment you will need the following items:

Solar Cell module

60W halogen lamp or high power rechargeable halogen torch

Digital Voltmeter or multimeter

Digital Ammeter or multimeter

Connecting leads

Measuring device such as a ruler or tape measure

Different shading materials

We previously learned that the connecting cells together in either parallel or series result in increased output power. But what happens if we cover or shade a cells exposed area from the Sun?

Set up a similar experiment as described in Experiment 1 (page 9). Then measure and set the distance from the cell to the halogen lamp to 10cms. Once again position the halogen lamp directly above the cell so to achieve its maximum efficiency. You should achieve similar results as before.

Position lamp directly above the cell

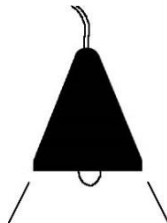

**10 centimetres**

Connect a multimeter



Next cover the cell about 10% with black paper or card as shown and record your results. Then continue to record your results with the card positioned at 50%, 75% and lastly 100%

# BrightSparks 4kids - Electricity & Solar Energy Teaching Guide

10% shaded area

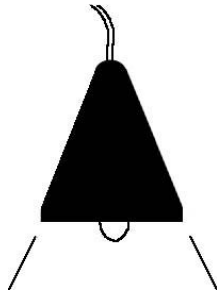

25% shaded area

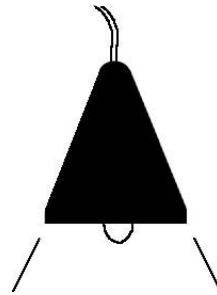

50% shaded area

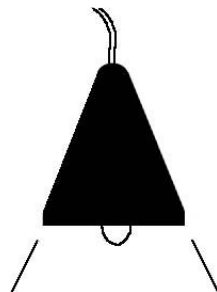

100% shaded area

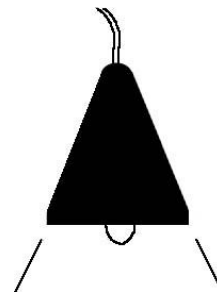

Note- Only shade across the cells area as indicated

# **BrightSparks 4kids - Electricity & Solar Energy Teaching Guide**

## **Results - Shading with various materials**

All results are dependent on which solar cell, light source and shading material you use. You can include your Solar cells model rating and light source in rating column below. (See page 22 for typical results)

<b><u>Solar Cell rating</u></b>			
<b><u>Lamp source rating</u></b>			
<b><u>Lamp Distance 10cms</u></b>	<b><u>Voltage reading</u></b>	<b><u>Current reading</u></b>	<b><u>Material used</u></b>
<b><u>No shading</u></b>			
<b><u>Shaded area 10%</u></b>			
<b><u>Shaded area 25%</u></b>			
<b><u>Shaded area 50%</u></b>			
<b><u>Shaded area 100%</u></b>			

Your results should be as a % of your output current across the cells surface.

For example a 100mA cell shaded to 50% across its exposed area with black card should produce an output of approximately 50mA.

**Now try this-** Try different shading materials such as glass, transparent cling film, or coloured transparent paper and see what effects this has on your results?

Are they any different?

Can you explain why?

## Cloudy weather & night time effects

When a cloud travels over a solar cells surface it reduces or stops the sunlight being absorbed. This can also be said about night time when it is dark. Therefore no voltage can be produced by the cell.

Potential problems occur if the voltage of the battery is higher than the solar cells voltage. For that time, current will flow in the opposite direction through the solar cell, thus draining the power from the battery it once helped to charge. To overcome this problem we need a special 'blocking' device called a **Diode**. A diode is a type of one way switch that only lets current flow in one direction. As we only need current to flow from the cell into the battery we can use the blocking diode as illustrated in the following example.

## Simple Battery Cell charging circuit

### Activity – 37 Construct the following circuit

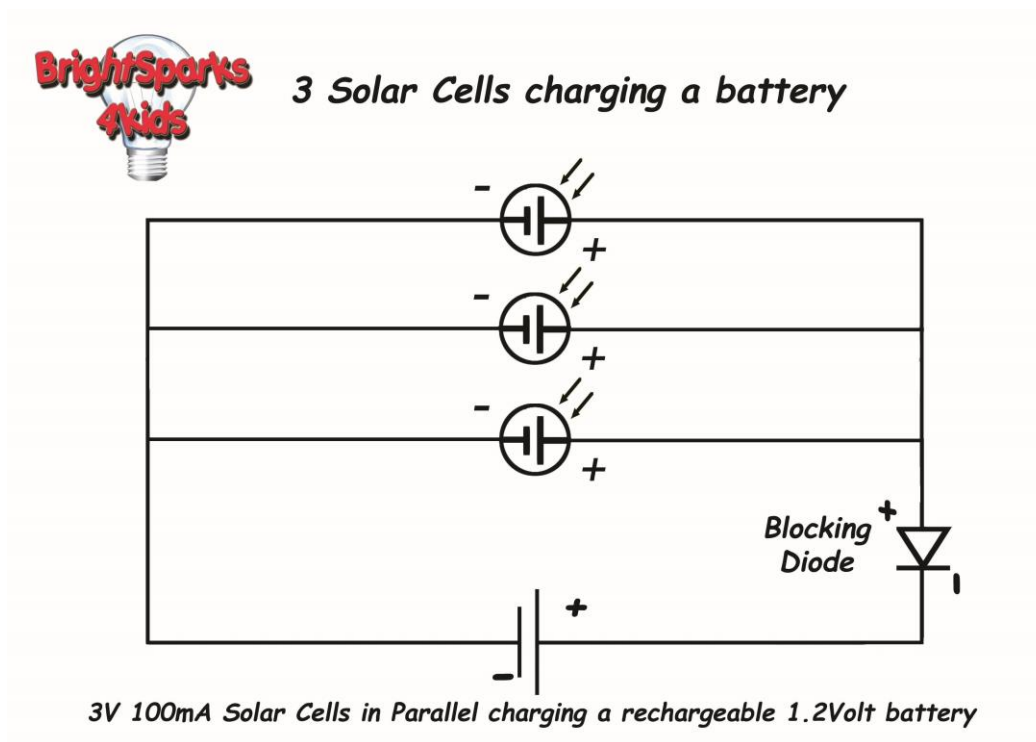

## **Charge times**

Batteries come in all voltages and capacities, usually the higher the capacity the longer it takes to fully charge and discharge. For this example we want to charge a single rechargeable AA battery with ratings of 1.2 V, capacity of 2700mA and use 3 x 3Volt 100mA. The Solar cells connected in parallel can potentially create a maximum current of 300mA. Charging time in direct sunlight would normally take around 10 hours to fully charge at 300mA although you could expect longer due to passing clouds.

For a Super Capacitor you would need to match the capacitors Voltage rating closely to the cell or cells being used. For example use a 5.5 Volt Solar cell to charge a 5V capacitor.



**Always- Observe the correct polarity when charging components**

**CAUTION- Never attempt to charge *NON Rechargeable batteries* or allow 'short circuiting' of the +/ - terminals. This is done by the + and - leads touching together and can result in excessive heat generation which may result in damage to component.**

**Activity 38 - Energy Wordsearch**



**Energy Wordsearch**

M R A F D N I W Y T J S  
D M H G H C S R S H Y O  
E N E R G Y E V T G U L  
I V F E W T I L E I U A  
O U M U T I H C L L V R  
L N O A X Y O A D N B P  
C D B Q N S Z A Q U T O  
A Z R Z C H K W D S Y W  
R E C H A R G E A B L E  
K J O T B H H N P T X R  
O O Q A C Q B D S W D X  
L W I N S R L T S Z X M

BATTERY  
ENERGY  
SUNLIGHT

CELL  
RECHARGEABLE  
WINDFARM

ECOSCHOOL  
SOLARPOWER

[www.brightsparks4kids.com](http://www.brightsparks4kids.com)

# **BrightSparks 4kids - Electricity & Solar Energy Teaching Guide**

## **Typical results**

### **Activity 30 - Typical results-**

Typical example applications of Solar cells

<b>Solar Cell applications</b>	<b>What is it used for and why?</b>
Calulator	Used to power the calculator and extend battery life
Satellite	Used to power the satellite in extreme remote locations where no off grid electricity is present
Traffic lights	Used to save energy and more cost effective to run
Street/car park lighting	Used to save energy and more cost effective to run
On buildings	Used to save energy and more cost effective to run
Battery chargers	Maintain and charge batteries
Concept cars	Powering non pollution cars of the future
On a boat	Used to power instruments where no off grid electricity is present
Mobile phone charger	Charge batteries
On hotels	Heating and hot water systems

### **Activity 32- Typical results**

All results are dependent on which solar module you are using and the power rating of your light source. These ratings can be recorded in the table columns below.

<b><u>Solar Cell rating</u></b>		
5.0V @100mA		
<b><u>Lamp used</u></b>		
60W Halogen		
<b><u>Lamp Distance</u></b>	<b><u>Voltage reading</u></b>	<b><u>Current reading</u></b>
<b><u>40 centimetres</u></b>	5.40 Volts	4.2 mA
<b><u>20 centimetres</u></b>	6.05 Volts	12.3 mA
<b><u>10 centimetres</u></b>	6.47 Volts	40.2 mA

# **BrightSparks 4kids - Electricity & Solar Energy Teaching Guide**

## **Activity 36 - Typical results**

All results are dependent on which solar cell, light source and shading material. You can include your Solar cells model rating and light source in rating column below.

<b><u>Solar Cell rating</u></b> 5.5V 100mA			
<b><u>Lamp source rating</u></b> 60W Halogen bulb			
<b><u>Lamp Distance 10cms</u></b>	<b><u>Voltage reading</u></b>	<b><u>Current reading</u></b>	<b><u>Material used</u></b>
<b><u>No shading</u></b>	6.47 Volts	40.2mA	Nothing
<b><u>Shaded area 10%</u></b>	6.36 Volts	36.15mA	Black card
<b><u>Shaded area 25%</u></b>	6.27 Volts	30.05mA	Black card
<b><u>Shaded area 50%</u></b>	6.14 Volts	20.05mA	Black card
<b><u>Shaded area 100%</u></b>	1.05 Volts	0.00mA	Black card

Your results should be as a % of your output current.



## **Solar Energy Facts**

- Solar energy is a completely free source of energy. Though the sun is 90 million miles from the earth, it takes less than 10 minutes for light to travel to us.
- The UK receives 5 times more energy from the Sun in June and July than in December and January.
- Space missions by various countries use solar energy to power their spaceships.
- A home solar panel system consists of several solar panels, an inverter, a battery, a charge regulator, wiring, and support materials. Sunlight is absorbed by the solar panels and is converted to electricity by the installed system. The battery stores electricity that can be used at a later time, like cloudy days or during the evening.
- Solar powered hot water systems utilize solar energy to heat water. In certain areas, 60 to 70% of water used domestically for temperatures as high as 60 degree Celsius can be made available by solar heating.
- Solar energy is being recognized as the future of alternative energy sources as it is nonpolluting and helps combat the Greenhouse effect on global climate created by use of fossils fuels.
- The largest solar power plant in the world is located in the Mojave Desert in California, covering 1000 acres.
- Solar power is noise pollution free. It has no moving parts, and does not require any additional fuel, other than sunlight, to produce power.
- The sun is also the main source of non-renewable fossil fuels (coal, gas and petroleum) which began life as plants and animals millions of years ago.

## **Glossary**

**Solar energy-** Energy from the sun

**Solar cell-** A single cell which converts its energy from the sun into electrical energy

**Solar panel-** Multiple cells connected together in either series or parallel converting their combined energy into electrical energy from the sun

**Voltage-** The electrical force in a circuit, measured in Volts (V)

**Current-** The movement of electrons in a circuit, measured in Amps or milliamps (mA)

**Power-** The electrical power in a circuit is the combined Voltage x Current (V x I) measured in Watts (W)

**Multimeter-** A device for measuring Voltage, current or resistance

**Motor-** A device which converts electrical energy into motion

**Buzzer-** A device which converts electrical energy into sound

**L.E.D-** A Light emitting diode or L.E.D is a device which converts electrical energy into light

**Photovoltaic-** A device that converts energy of light directly into electricity by the photovoltaic effect

**Series circuit-** Series circuits have only one path for current to flow to complete the circuit. Current must flow through every component to complete its loop

**Parallel circuit-** Parallel circuits have many paths for current to flow to complete the circuit. Current flows through each component directly and is therefore not affected by the other components

## **Intended Usage & Storage:**

This kit contains some small parts and should NOT be given to children under the age of 3



### **WARNING:**

**CHOKING HAZARD** — Small parts not for children under 3 years or any individuals who have a tendency to place inedible objects in their mouths.

The kit/contents and all its modules are solely intended for **LOW VOLTAGE BATTERY USE ONLY** and should – **UNDER NO CIRCUMSTANCE BE CONNECTED TO ANY MAINS ELECTRICITY SUPPLY.**

The battery terminals are **NOT** to be short circuits.

The batteries in this kit should be removed after use and NOT stored for long periods of time in the kit.

Only use the batteries intended as detailed in this User Guide.

Avoid using new or used batteries or mixing different types of batteries. (I.e. Alkaline & Carbon-Zinc)

Batteries are to be inserted the correct polarity.

Rechargeable batteries should not be charged or used with this kit.

Exhausted batteries are to be removed from the Kit and disposed of correctly.

Batteries and electronics are harmful to the environment and should be disposed of correctly, either to the manufacturer or a local collection centre for recycling.

## **Warranty of product:**

*12 months from date of sale*

**BrightSparks 4kids** warrant its products will be free from defects in materials, design and workmanship for a period of 12 months from the date of sale. If a product proves defective during this warranty period, BrightSparks 4kids, on its opinion, will either repair the defective product without charge for parts and labour, or will provide a replacement in exchange for the defective product. In order to obtain service under this warranty the Customer must promptly notify BrightSparks 4Kids in writing upon discovery of the defect before the expiration of the warranty period and make suitable arrangements with BrightSparks 4kids indicating either purchase date/serial number or batch identification prior to returning the item. The Customer shall be responsible for packaging and shipping the defective product to BrightSparks 4Kids. The Customer shall also be responsible for paying all duties, taxes, and any other charges required in order to ship the product.

The warranty does not apply to any defect, failure or damage caused by improper use or improper or inadequate maintenance and care. BrightSparks 4Kids shall not be obligated to repair/replace a product under this warranty a) to repair damage resulting from attempts by personnel other than BrightSparks 4kids, either to repair or service the product; b) to repair/replace damage resulting from improper use or connection to incompatible equipment; c) to repair/replace any damage or malfunction caused by the use of non-BrightSparks 4Kids products being used in-conjunction with the product: d) used in any manner which is not in accordance with the manufacturer's operating or user instructions or from any failure to service or maintain the Goods in accordance with the manufacturer's instructions: e) any use of or dealing with the product in a manner which could not reasonably be expected having regard to their normal purpose.

## **Environment:**

**Brightsparks 4kids** understand the sustainability principles of **Reduce, Reuse & Recycle**. As a result we are committed to re-cycling and reducing as much of our waste as possible. All recyclable materials such as paper, cardboard, packaging materials, printer inks & toners etc. will be re-used where appropriate or disposed of properly.

In order for us to do this effectively and reduce the amount of waste we produce we also aim to re-cycle any appropriate packaging material we receive and re-use with the packaging of our products thus reducing our carbon footprint.



### ***Disposal of electrical & electronic equipment***

Do not dispose of these product/products in household waste. For the proper treatment, recovery and recycling please take these product/products to the appropriate collection point.

If you are unsure of where this is please contact your local authority. Improper disposal may be harmful to the environment.



You may also return your used or unwanted **Brightsparks 4kids** products directly back to this company for us to dispose of correctly or re-cycle as we see fit.

For returning unwanted products please notify us in advance at [re-cycle@brightsparks4kids.com](mailto:re-cycle@brightsparks4kids.com) before sending any goods.

Please note the Customer shall be responsible for packaging and shipping of any used or unwanted product.

Version 4a